

## Data Quantizer

### Description

U6792B-E data quantizer is a low-noise, wideband IC for signal recovering in fiber optic receiver systems. It contains a three stage wideband limiting amplifier which accepts input signal as low as 1.5 mV<sub>pp</sub> with a 60 dB dynamic range. This sensitivity is achieved by using a dc

restoration feedback loop which nulls any offset voltage produced in the limiting amplifier. The ECL output buffer can drive 50 Ω loads to -2 V. The minimum signal discriminator circuit provides a link monitor function with a user selectable threshold voltage.

### Features

- 200-MHz minimum bandwidth allows for data rates of up to 200 Mb/s
- Low-noise design: 25 μV RMS over 200-MHz range
- Adjustable link monitor function
- Wide 60-dB input dynamic range
- 2.5 ns minimum input pulse
- Low-power design: 30 mA maximum without load
- Regulated voltage output for supply voltage independent threshold adjust
- Available in SO-16 package or chip form

### Block Diagram

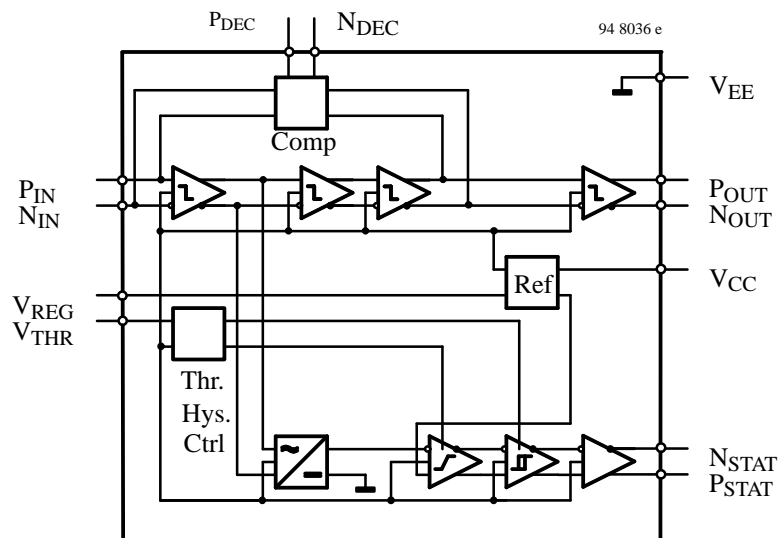

## Pin Description

Pin	Symbol	Function
1, 2	V <sub>CC</sub>	Positive supply voltage
3,4	P <sub>IN</sub> , N <sub>IN</sub>	Capacitively coupled to the input source or to ground (the input resistance is approximately 5 kΩ)
5, 6	V <sub>CC</sub>	Positive supply voltage
7	V <sub>REG</sub>	3.1 V reference voltage with respect to V <sub>EE</sub> (should be decoupled with min. 10 nF to V <sub>EE</sub> .)
8	V <sub>THR</sub>	Threshold adjusting for the link monitor circuit
9, 10	V <sub>EE</sub>	Negative supply voltage
11	N <sub>STAT</sub>	Negative ECL compatible link monitor output
12	P <sub>STAT</sub>	Positive ECL compatible link monitor output
13,14	P <sub>DEC</sub> , N <sub>DEC</sub>	A decoupling capacitor must be connected between these pins
15	N <sub>OUT</sub>	Negative ECL compatible output
16	P <sub>OUT</sub>	Positive ECL compatible output

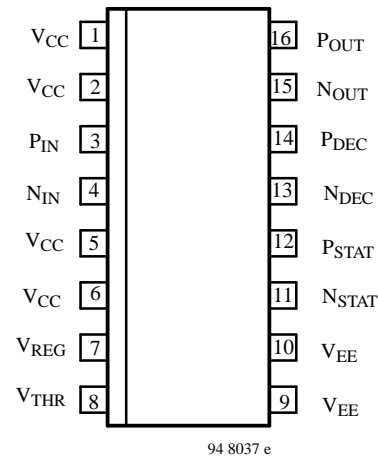

## Absolute Maximum Ratings

Parameters	Symbol	Value	Unit
Supply voltage Pins 9 and 10	V <sub>EE</sub>	6.0	V
Input voltage Pins 3, 4, 8, 13 and 14	V <sub>i</sub>	V <sub>EE</sub> to GND	V
Junction temperature	T <sub>j</sub>	125	°C
Storage temperature range	T <sub>stg</sub>	-40 to +125	°C

## Operating Range

Parameters	Symbol	Value	Unit
Supply voltage range Pins 9 and 10	V <sub>EE</sub>	4.5 to 5.7	V
Ambient temperature range	T <sub>amb</sub>	-40 to +85	K/W

## Thermal Resistance

Parameters	Symbol	Value	Unit
Junction ambient SO-16	R <sub>thJA</sub>	typ. 120	°C

### DC Electrical Characteristics

Operating conditions:  $T_{amb} = 0^{\circ}\text{C}$  to  $70^{\circ}\text{C}$ ,  $V_{EE} = -5.2\text{V} \pm 10\%$

Parameters	Test Conditions / Pins	Symbol	Min.	Typ.	Max.	Unit
$V_{EE}$ supply current	Unloaded outputs	$I_{EE}$	-30	-23		mA
Reference voltage *		$V_{REG}$	3.10	3.15	3.20	V
$V_{REG}$ output current		$I_{EE}$			100	$\mu\text{A}$
Voltage at $V_{THR}$ *	Left open	$V_{THRO}$		0.45		V
Voltage Range of $V_{THR}$		$V_{THRR}$	0		$V_{REG}$	V
Input offset voltage		$V_{OS}$			1	mV
Input resistance	$V_{IN,NIM}$	$R_{IN,NIN}$		5		k $\Omega$
Output high level at $P_{OUT}, N_{OUT}, P_{STAT}, N_{STAT}$	With 50 $\Omega$ load to -2 V	$V_{OH}$	-0.98		-0.7	V
Output low level at $P_{OUT}, N_{OUT}, P_{STAT}, N_{STA}$	With 50 $\Omega$ load to -2 V	$V_{OL}$	-1.89		-1.62	V
Hysteresis of monitor comparator	Over entire range of $V_{THR}$	$V_{HYS}$	3	4		dB

\* With reference to  $V_{EE}$

### AC Electrical Characteristics

Operating conditions:  $T_{amb} = 0^{\circ}\text{C}$  to  $70^{\circ}\text{C}$ ,  $V_{EE} = -5.2\text{V} \pm 10\%$

Parameters	Test Conditions / Pins	Symbol	Min.	Typ.	Max.	Unit
Input voltage range		$V_{IN}$	1.5		1500	mV <sub>pp</sub>
Input reference noise		$N_T$		25		$\mu\text{V}$
Rise time at $P_{OUT}, N_{OUT}, P_{STAT}, N_{STAT}$	With 50 $\Omega$ load to -2 V	$t_r$	1.1		1.9	ns
Fall time at $P_{OUT}, N_{OUT}, P_{STAT}, N_{STA}$	With 50 $\Omega$ load to -2 V	$t_f$	1.1		1.9	ns
Propagation time		$t_{pd}$	2		4	ns
Bandwidth		BW	200			MHz

## Functional Description

### Amplifier Stage

This data quantizer has a three stage limiting amplifier with an input common mode range of  $V_{EE} + 1.8 \text{ V}$  to  $V_{CC} - 1.0 \text{ V}$ . Maximum sensitivity is achieved through the use of a dc restoration feedback loop and ac coupling the input. When ac coupled, the input dc bias voltage is set by the limiting amplifier itself at about  $-2.1 \text{ V}$ . The differential input requires two capacitors of equal value. For single ended operation, one of the coupling capacitors has to be connected to ground.

An external capacitor between  $P_{DEC}$  and  $N_{DEC}$  is used to store the internal offset voltage. The value of this capacitor is not critical. In order to avoid stability problems, the value of this capacitor should be at least the same as the coupling capacitors.

### Link Monitor

The link monitor function is implemented by the minimum signal discriminator and the threshold generator circuits. The purpose of this function is to monitor the input signal and to provide a status signal indicating when the input signal falls below or rises above a preset voltage level. This is done by peak detecting the output of the first stage of the limiting amplifier and comparing this level with the internal threshold voltage set by  $V_{THR}$ .

If  $V_{THR}$  is left open, the typical threshold level is  $2.85 \text{ mV}$ . The on-chip reference voltage,  $V_{REG}$ , can be used to adjust the voltage at  $V_{THR}$  by dividing  $V_{REG}$  with a resistor string.

## Typical Application

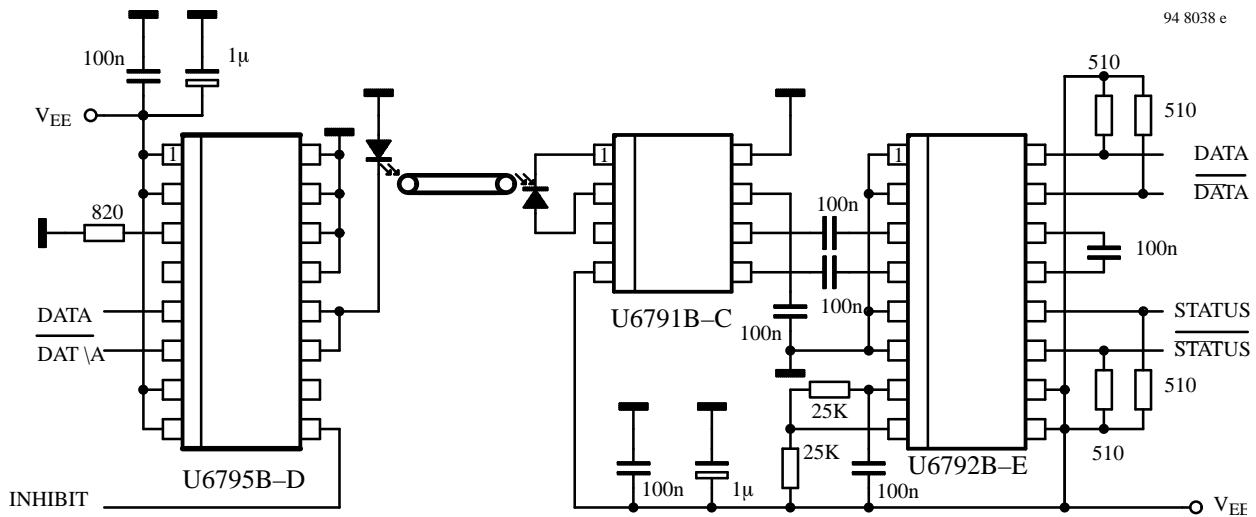

### Typical Characteristics ( $T_{amb} = 25^{\circ}\text{C}$ )

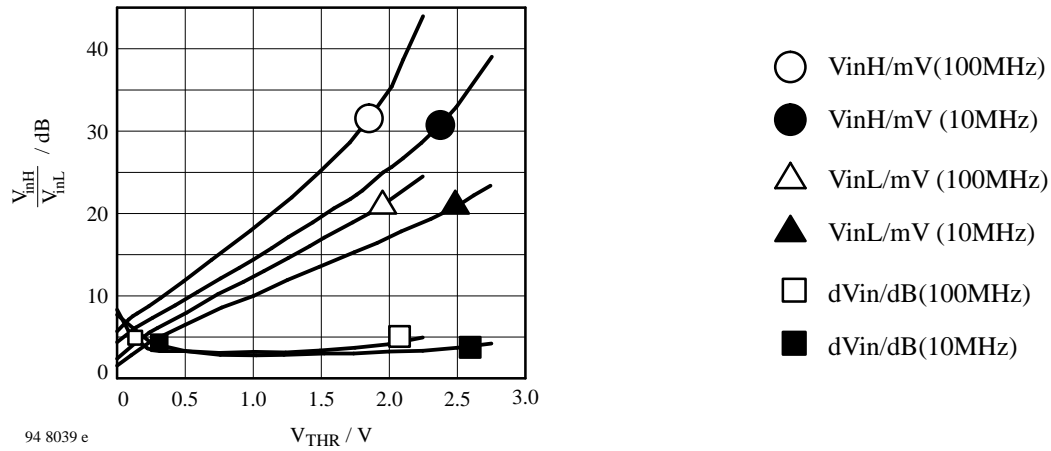
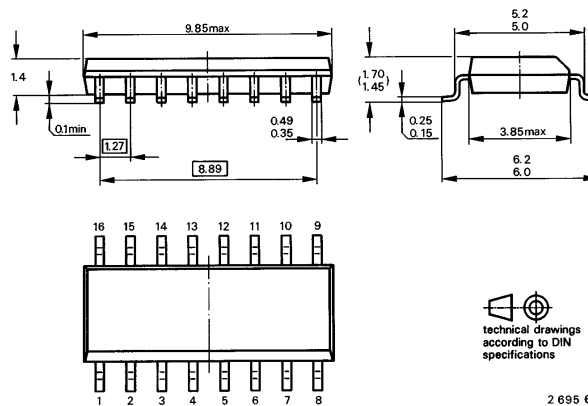

Figure 1 Threshold levels and hysteresis vs. threshold voltage

### Dimensions in mm

Package: SO 16



## Ozone Depleting Substances Policy Statement

It is the policy of **TEMIC TELEFUNKEN microelectronic GmbH** to

1. Meet all present and future national and international statutory requirements.
2. Regularly and continuously improve the performance of our products, processes, distribution and operating systems with respect to their impact on the health and safety of our employees and the public, as well as their impact on the environment.

It is particular concern to control or eliminate releases of those substances into the atmosphere which are known as ozone depleting substances (ODSs).

The Montreal Protocol (1987) and its London Amendments (1990) intend to severely restrict the use of ODSs and forbid their use within the next ten years. Various national and international initiatives are pressing for an earlier ban on these substances.

**TEMIC TELEFUNKEN microelectronic GmbH** semiconductor division has been able to use its policy of continuous improvements to eliminate the use of ODSs listed in the following documents.

1. Annex A, B and list of transitional substances of the Montreal Protocol and the London Amendments respectively
2. Class I and II ozone depleting substances in the Clean Air Act Amendments of 1990 by the Environmental Protection Agency (EPA) in the USA
3. Council Decision 88/540/EEC and 91/690/EEC Annex A, B and C (transitional substances) respectively.

**TEMIC** can certify that our semiconductors are not manufactured with ozone depleting substances and do not contain such substances.

**We reserve the right to make changes to improve technical design and may do so without further notice.**

Parameters can vary in different applications. All operating parameters must be validated for each customer application by the customer. Should the buyer use TEMIC products for any unintended or unauthorized application, the buyer shall indemnify TEMIC against all claims, costs, damages, and expenses, arising out of, directly or indirectly, any claim of personal damage, injury or death associated with such unintended or unauthorized use.

TEMIC TELEFUNKEN microelectronic GmbH, P.O.B. 3535, D-74025 Heilbronn, Germany  
Telephone: 49 (0)7131 67 2831, Fax number: 49 (0)7131 67 2423